

MANUAL TRANSMISSION

SECTION **MT**

CONTENTS

PREPARATION	2	DISASSEMBLY	14
Special Service Tools	2	Case Components	14
Commercial Service Tools	4	Shift Control Components	15
TRANSMISSION FS5R30A	5	Gear Components	16
Replacing the Rear Oil Seal.....	5	INSPECTION	21
		Shift Control Components	21
		Gear Components	21
		ASSEMBLY	23
		Gear Components	23
		Shift Control Components	31
		Case Components	32
		SERVICE DATA AND SPECIFICATIONS (SDS)	34
		General Specifications.....	34
		Inspection and Adjustment	35

FS5R30A

MT

PREPARATION

Special Service Tools

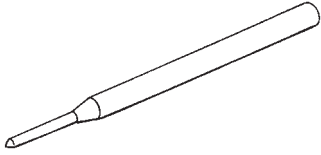
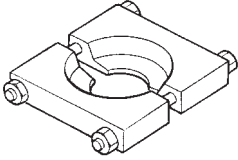
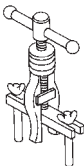
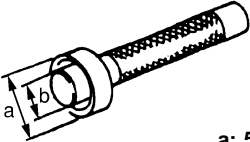
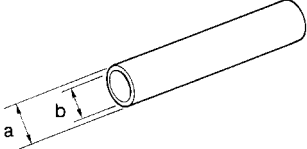
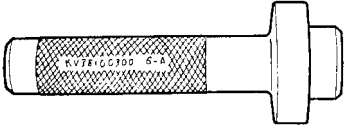
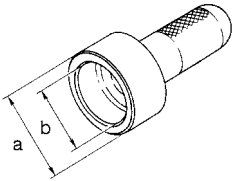

*: Special tool or commercial equivalent

Tool number Tool name	Description	
ST23540000* Pin punch		Removing and installing retaining pin
ST30031000* Puller		Removing 1st & 2nd synchronizer assembly Removing counter gear rear thrust bearing Removing main drive bearing
ST33290001* Puller		Removing rear oil seal
ST33230000* Drift	 <p style="text-align: center;"> a: 51 mm (2.01 in) dia. b: 28.5 mm (1.122 in) dia. </p>	Removing mainshaft and counter gear
ST22350000* Drift	 <p style="text-align: center;"> a: 34 mm (1.34 in) dia. b: 28 mm (1.10 in) dia. </p>	Removing counter gear front bearing (Use with KV38100300)
KV38100300* Drift	 <p style="text-align: center;"> a: 54 mm (2.13 in) dia. b: 32 mm (1.26 in) dia. </p>	Removing counter gear front bearing (Use with ST22350000) Installing counter gear rear bearing
ST30720000* Drift	 <p style="text-align: center;"> a: 77 mm (3.03 in) dia. b: 55.5 mm (2.185 in) dia. </p>	Removing mainshaft front bearing Installing mainshaft front bearing

PREPARATION

Special Service Tools (Cont'd)

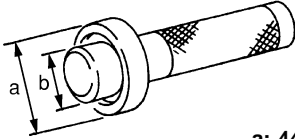
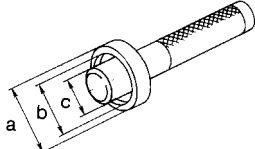
*: Special tool or commercial equivalent

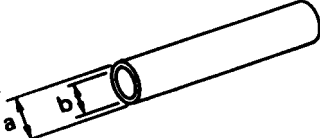
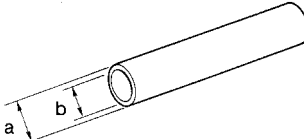
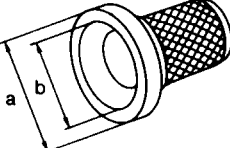
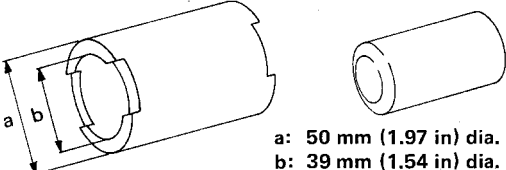
Tool number Tool name	Description
ST33210000* Drift	 <p style="text-align: center;">a: 44 mm (1.73 in) dia. b: 24.5 mm (0.965 in) dia.</p>
ST33220000* Drift	 <p style="text-align: center;">a: 37 mm (1.46 in) dia. b: 22 mm (0.87 in) dia.</p>
ST30613000* Drift	 <p style="text-align: center;">a: 72 mm (2.83 in) dia. b: 48 mm (1.89 in) dia.</p>
ST37750000* Drift	 <p style="text-align: center;">a: 40 mm (1.57 in) dia. b: 31 mm (1.22 in) dia.</p>
ST22452000* Drift	 <p style="text-align: center;">a: 40 mm (1.57 in) dia. b: 36 mm (1.42 in) dia.</p>
ST33400001* Drift	 <p style="text-align: center;">a: 60 mm (2.36 in) dia. b: 47 mm (1.85 in) dia.</p>
ST36730000* Drift	 <p style="text-align: center;">a: 50 mm (1.97 in) dia. b: 39 mm (1.54 in) dia.</p> <p style="text-align: center;">a: 50 mm (1.97 in) dia. b: 39 mm (1.54 in) dia.</p>

PREPARATION

Commercial Service Tools

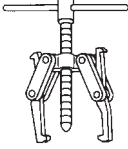
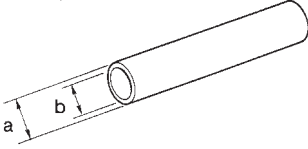
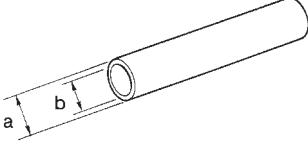
Tool name	Description
Puller	 <p>Removing counter gear rear end bearing Removing mainshaft rear bearing Removing reverse synchronizer hub Removing reverse counter gear</p> <p>NT077</p>
Drift	 <p>Installing sub-gear snap ring</p> <p>ST22452000</p> <p>a: 44.5 mm (1.752 in) dia. b: 38.5 mm (1.516 in) dia.</p>
Drift	 <p>Installing OD main gear Installing reverse gear bushing</p> <p>ST22452000</p> <p>a: 44.5 mm (1.752 in) dia. b: 40.5 mm (1.594 in) dia.</p>

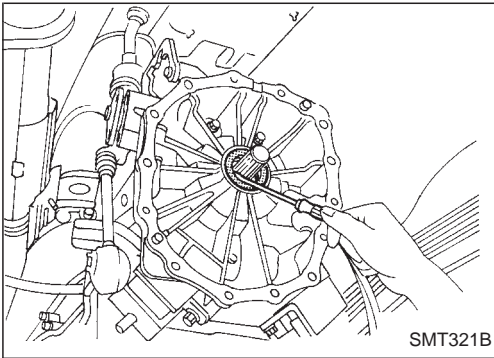

Replacing the Rear Oil Seal

REMOVAL

1. Remove transfer assembly. See Section TF.
2. Remove rear oil seal.

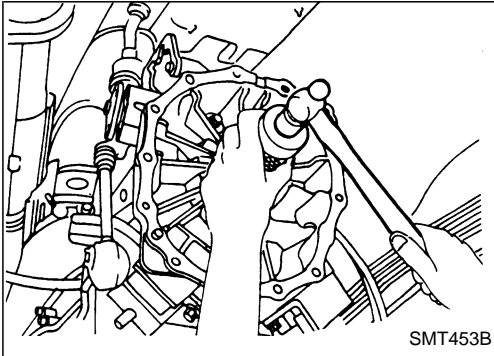

REPLACEMENT

1. Install rear oil seal.
Before installation, apply multi-purpose grease to oil seal lip.
2. Install transfer assembly. See Section TF.

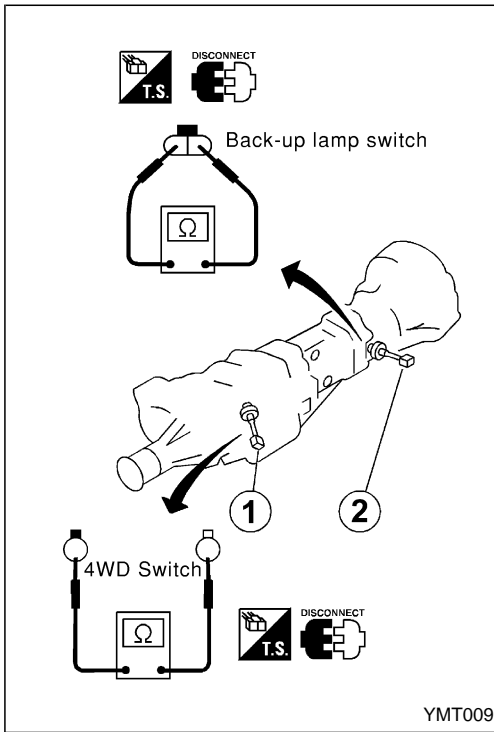

Check of Position Switches

Switch		Gear position	Continuity	
①	4WD*	Transfer case	4WD	Yes
			Except 4WD	No
②	Back-up lamp	Transmission case	Reverse	Yes
			Except reverse	No

*: Ensure both sides of 4WD 2-pole double-throw switch is operational, refer to "Warning lamps" wiring diagram in EL-Section.

Removal

Transmission has to be removed as a unit together with transfer box.

Remove transmission assembly as follows:

- Disconnect negative battery terminal.
- Remove shift levers of transmission and transfer.
- Remove front and rear propeller shafts. — Refer to PD section.
- **Insert plug into rear oil seal after removing propeller shaft.**
- **Remove RPM-sensor from transmission upper side.**

CAUTION:

Be careful not to damage spline, sleeve yoke and rear oil seal, when removing propeller shaft.

- Remove torsion bar spring. — Refer to FA Section.
- Remove third crossmember (the one supporting front differential).
- Remove fifth crossmember (the one situated at the rear of transfer).
- Support transmission and transfer with a suitable transmission jack.

WARNING:

Support transmission and transfer with suitable jacks, while removing them.

- Remove fourth crossmember (the one supporting transmission).
- Remove clutch operating cylinder.
- Remove starter motor.
- Remove exhaust tube bracket from transmission.
- Disconnect electrical connectors.
- Remove transmission from engine.

Installation

Transmission has to be installed as a unit together with transfer box.

Install transmission assembly as follows:

- Apply sealant as below:

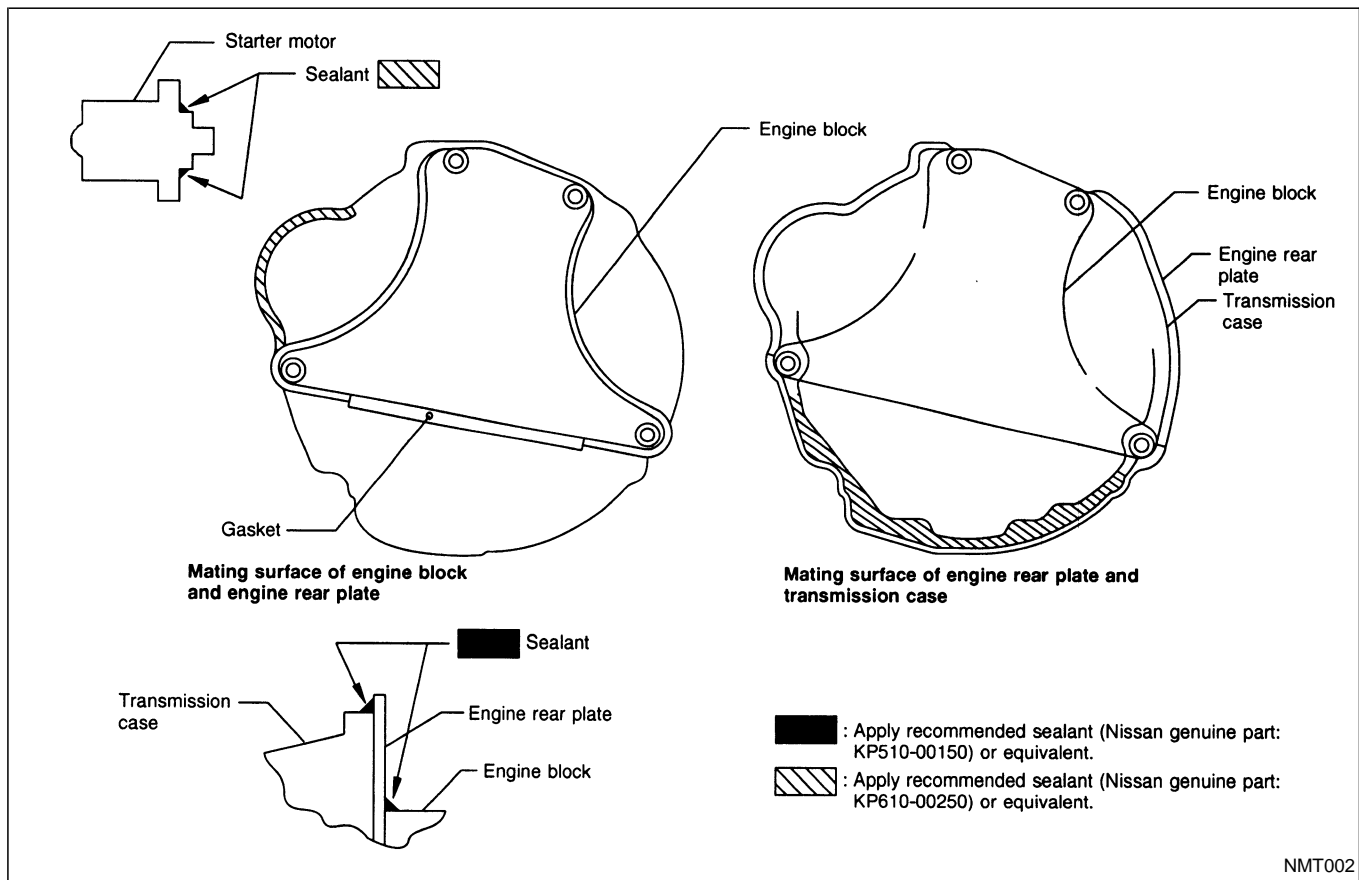

NMT002

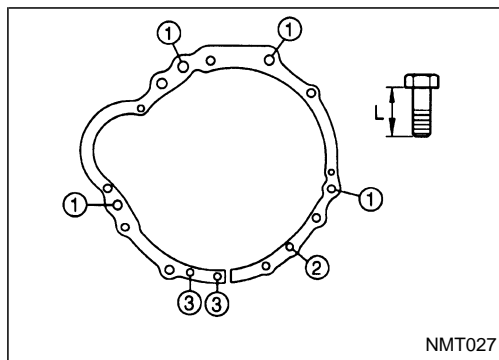



Bolt No.	Tightening torque N·m (kg·m, ft·lb)	Bolt length "L" - mm (in)
1	39 - 49 (4.0 - 5.0, 29 - 36)	57 (2.244)
2	18 - 22 (1.9 - 2.2, 14 - 16)	11 (0.433)
3	29 - 39 (3.0 - 4.0, 22 - 29)	100 (3.94)

Installation (Cont'd)

- Raise the unit with a hoist.
- Position the transmission assembly on a portable jack and secure it with a suitable tool.
Lift the assembly until the gearbox input shaft faces its housing.

Move the assembly towards the engine. The assembly must be rotated slightly so that the starter motor housing clears the projection on the companion floor. Insert input shaft into its housing (slightly raising the rear of the transfer box may facilitate the introduction of the shaft into its housing).

- Tighten the screws securing the gearbox to the engine.
: **39 - 49 N·m (4.0 - 5.0 kg-m, 29 - 36 ft-lb)**
- Connect the electrical wiring. Secure with the respective clips.
- Fit the RPM-sensor to the transmission upper side.
- Fit the exhaust pipe support bracket to the transfer box.
: **13 - 16 N·m (1.3 - 1.6 kg-m, 9 - 12 ft-lb)**
- Fit the starter motor. Secure the earth wire to the starter motor lower screw.

- Fit the clutch slave cylinder.
: **31 - 41 N·m (3.2 - 4.2 kg-m, 23 - 30 ft-lb)**

- Fit the clutch slave cylinder.
: **30 - 40 N·m (3.1 - 4.1 kg-m, 22 - 30 ft-lb)**
- Install fourth crossmember (Note the "front" mark).

Crossmember fixing bolts to chassis:

: **41 - 52 N·m (4.2 - 5.3 kg-m, 30 - 38 ft-lb)**

Crossmember fixing bolts to transmission:

: **68 - 87 N·m (6.9 - 8.9 kg-m, 50 - 64 ft-lb)**

- Take away the portable jack holding boxes assembly.
- Install fifth crossmember.
: **59 - 78 N·m (6.0 - 8.0 kg-m, 43 - 58 ft-lb)**
- Install third crossmember.

: **Screws: 41 - 52 N·m (4.2 - 5.3 kg-m, 30 - 38 ft-lb)**

Nuts: 68 - 87 N·m (6.9 - 8.9 kg-m, 50 - 64 ft-lb)

- Install torsion bar springs. — Refer to FA section.
- Install front and rear propeller shafts. — Refer to PD section.
- Install shift levers of transmission and transfer.
: **14 - 18 N·m (1.4 - 1.8 kg-m, 10 - 13 ft-lb)**

Bolt head dimensions:

Bolt A: 12 mm (0.472 in)

Bolt B: 13 mm (0.512 in)

- Connect negative battery cable.

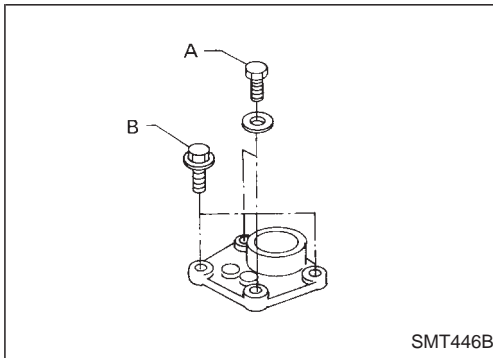

Case Components

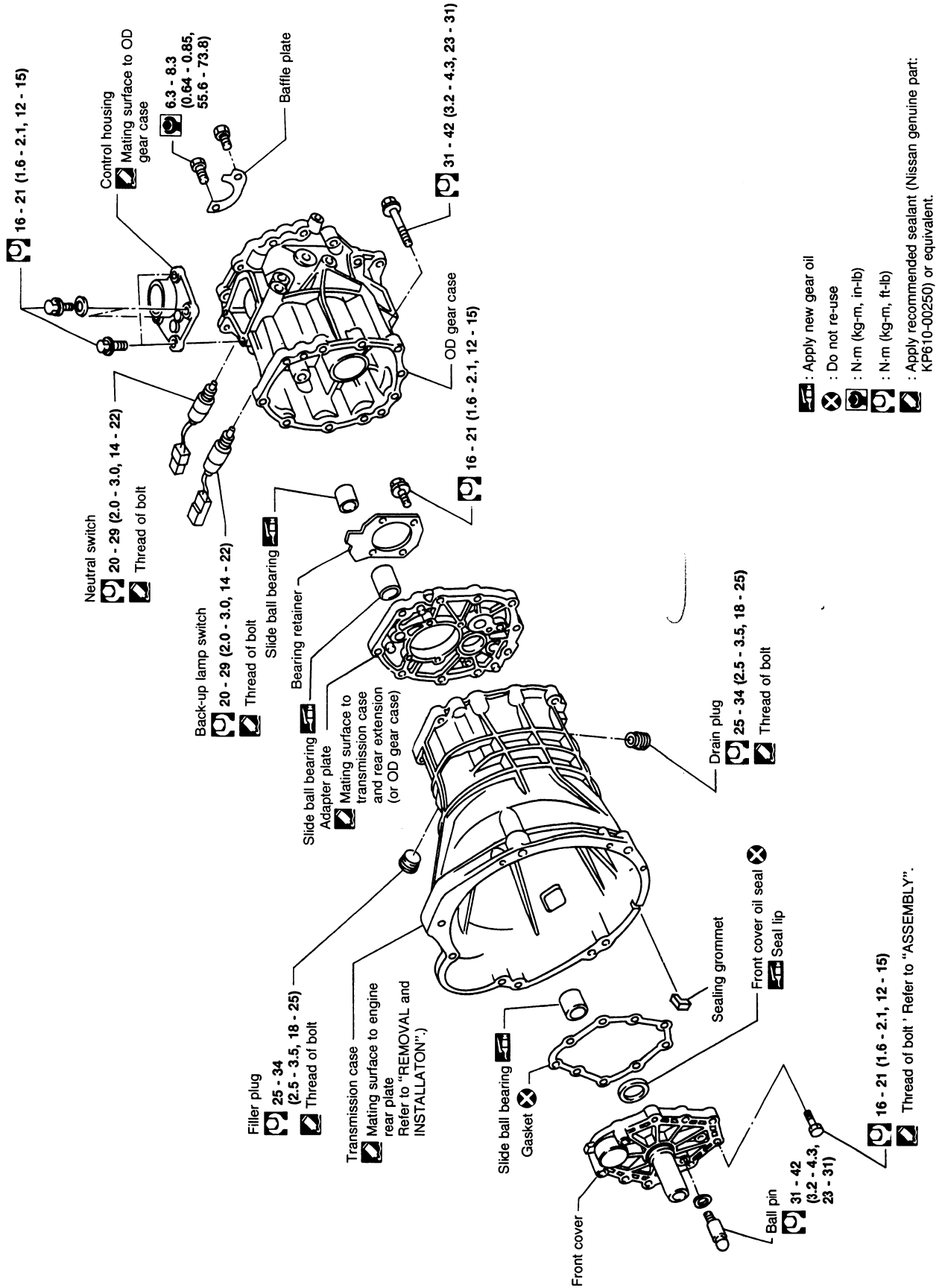

- : Apply new gear oil
- : Do not re-use
- : N·m (kg-m, in-lb)
- : N·m (kg-m, ft-lb)
- : Apply recommended sealant (Nissan genuine part: KP610-00250) or equivalent.

Gear Components

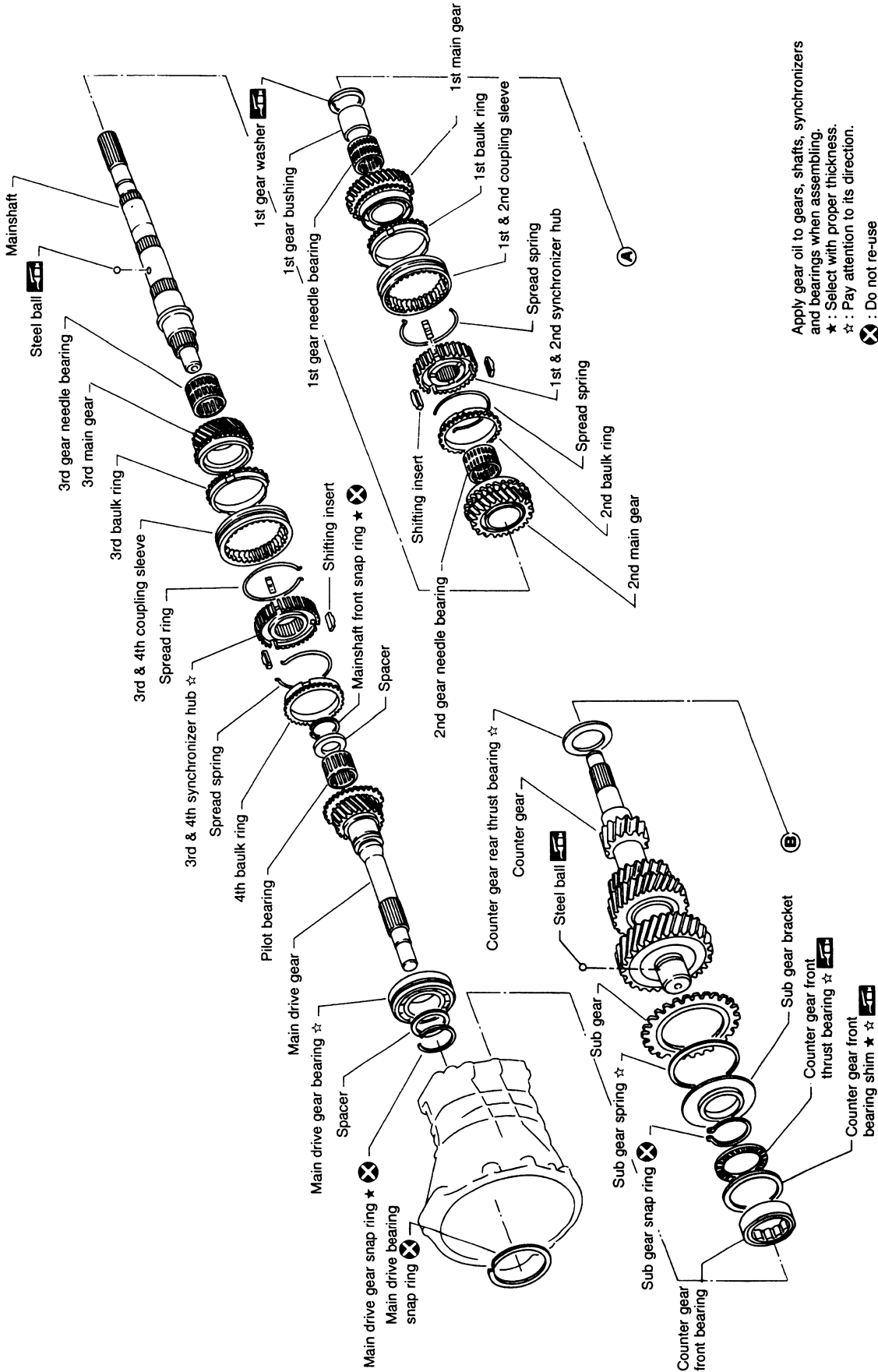

Apply gear oil to gears, shafts, synchronizers and bearings when assembling.
 ★ : Select with proper thickness.
 ☆ : Pay attention to its direction.
 ⊗ : Do not re-use
 ⊠ : Apply new gear oil

Gear Components (Cont'd)

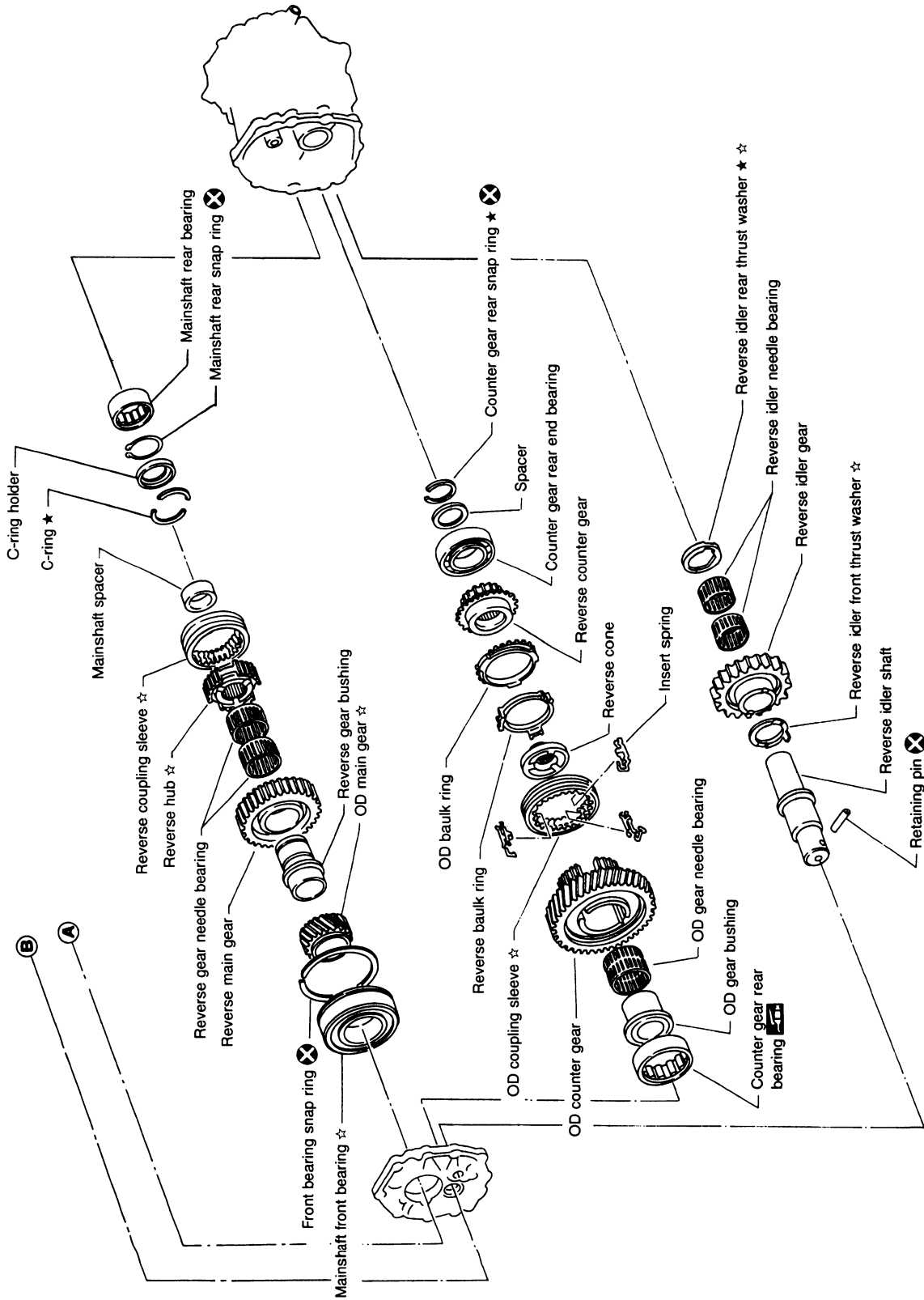

Shift Control Components

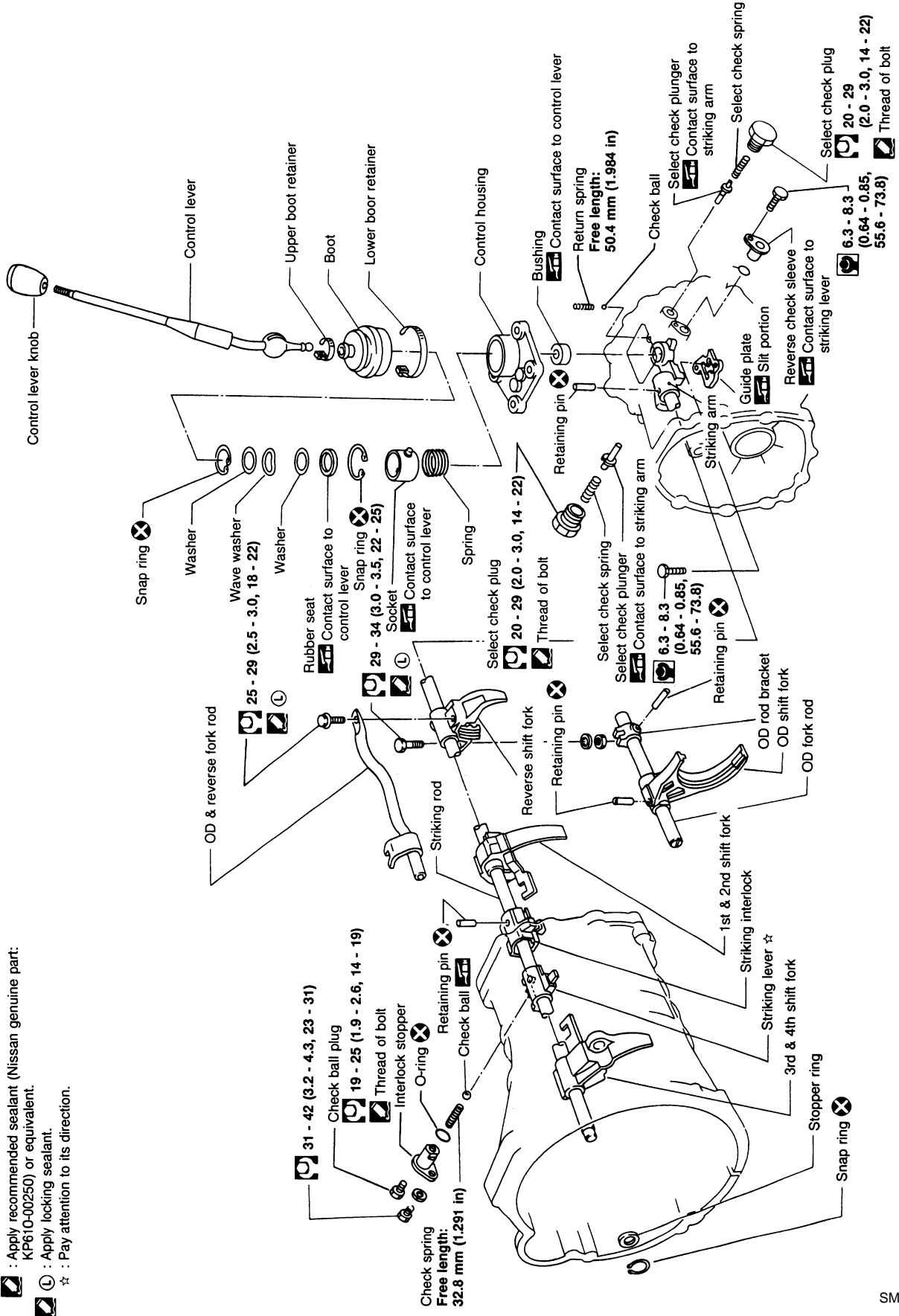

Ⓜ : N·m (kg·m, in·lb)
Ⓝ : N·m (kg·m, ft·lb)
Ⓜ : Apply recommended sealant (Nissan genuine part: KP610-00250) or equivalent.
Ⓝ : Apply locking sealant.
☆ : Pay attention to its direction.

DISASSEMBLY

Case Components

1. Remove check ball plug, check spring and check ball. Then remove interlock stopper.

If interlock assembly is removed as a unit, the check ball can fall into transmission case.

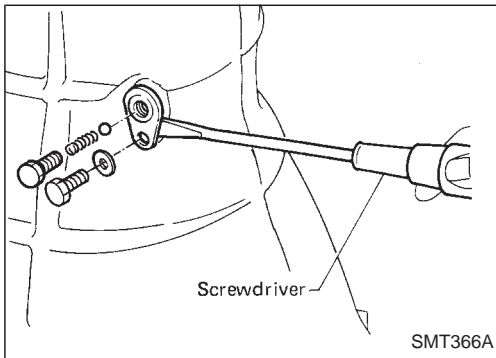

2. Remove control housing, return spring and check ball.

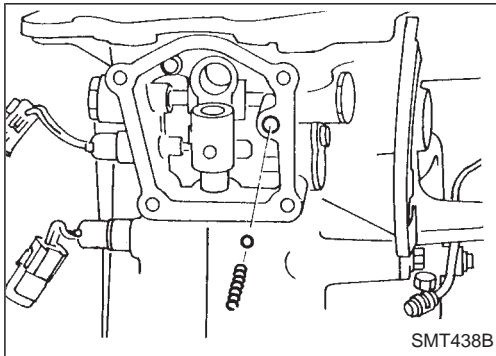

3. Drive out retaining pin from striking arm.

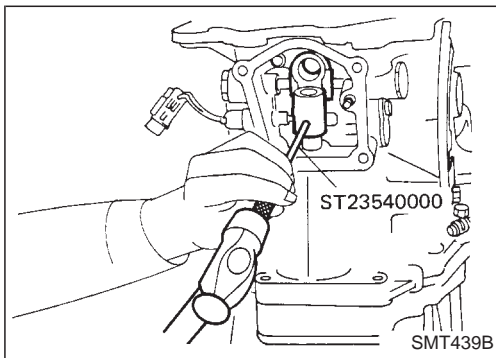

4. Remove OD gear case together with striking arm by tapping lightly.

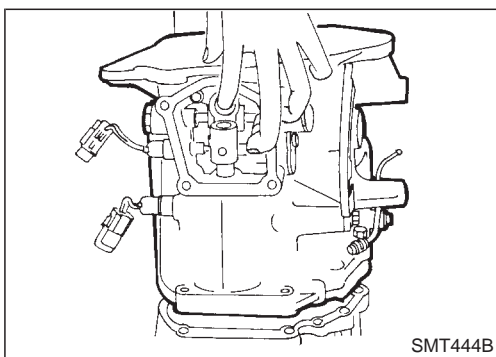
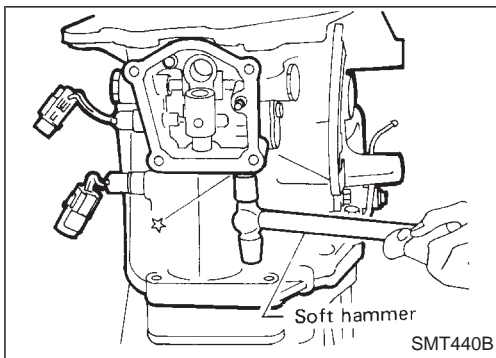

DISASSEMBLY

Case Components (Cont'd)

5. Remove front cover and gasket.

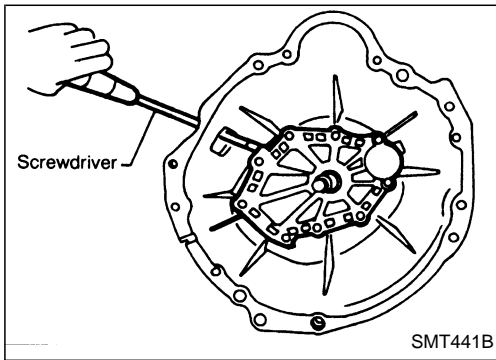

6. Remove stopper ring and main drive bearing snap ring.

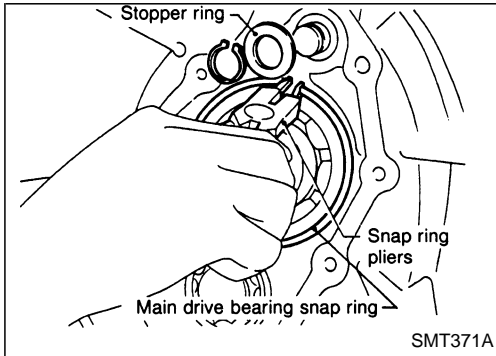

7. Remove transmission case by tapping lightly.

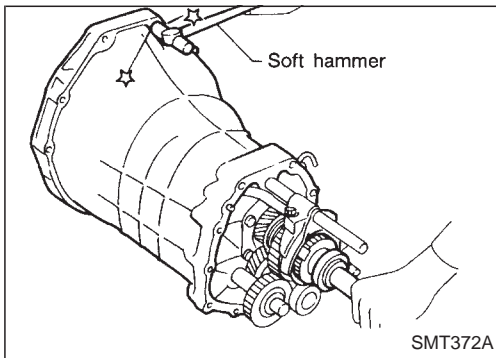

8. Remove front cover oil seal.

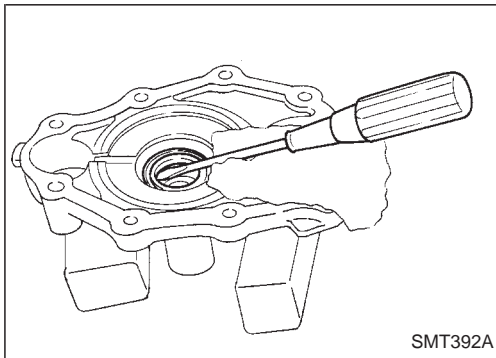

Shift Control Components

1. Mount adapter plate on vise.
2. Remove OD & reverse fork rod.

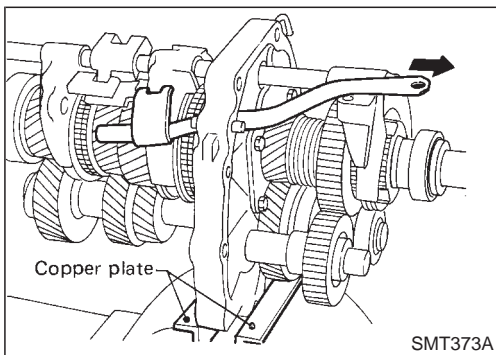

DISASSEMBLY

Shift Control Components (Cont'd)

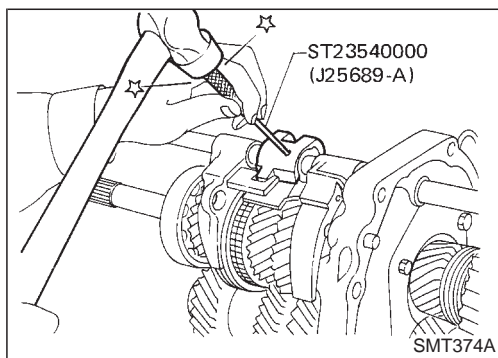

3. Drive out retaining pin from striking lever.
4. While pulling out striking rod, remove striking lever and striking interlock. Then remove 1st & 2nd, 3rd & 4th and reverse shift fork.

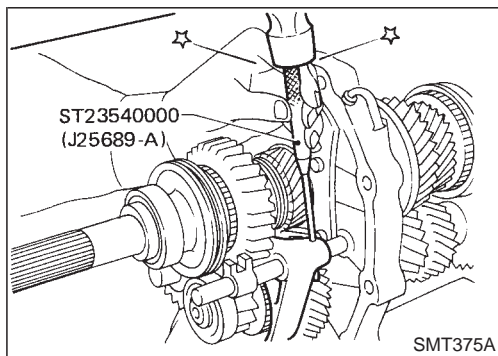

5. Drive out retaining pin from OD shift fork.
6. Pull out OD fork rod and then remove OD shift fork.

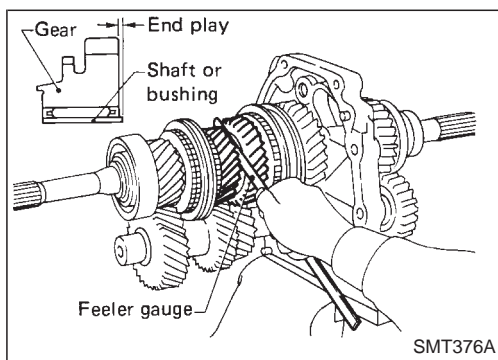

Gear Components

1. Before removing gears and shafts, measure each gear end play.

Gear	End play mm (in)
1st main gear	0.23 - 0.33 (0.0091 - 0.0130)
2nd main gear	0.23 - 0.33 (0.0091 - 0.0130)
3rd main gear	0.23 - 0.33 (0.0091 - 0.0130)
OD counter gear	0.23 - 0.33 (0.0091 - 0.0130)
Reverse main gear	0.33 - 0.43 (0.0130 - 0.0169)

- If not within specification, disassemble and check contact surface of gear to hub, washer, bushing, needle bearing and shaft.

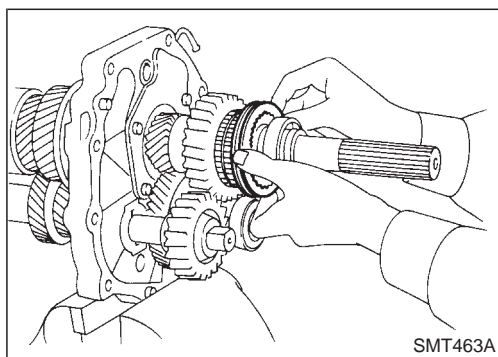

2. Remove rear side components on mainshaft and counter gear.
 - a. Remove reverse coupling sleeve.

DISASSEMBLY

Gear Components (Cont'd)

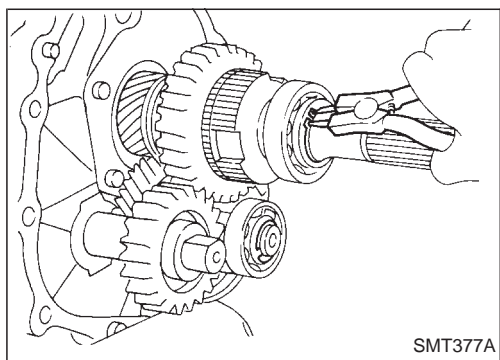

- b. Remove mainshaft rear snap ring and counter gear snap ring.
- c. Remove C-ring holder and mainshaft C-rings from mainshaft. Use punch and hammer to remove C-rings.

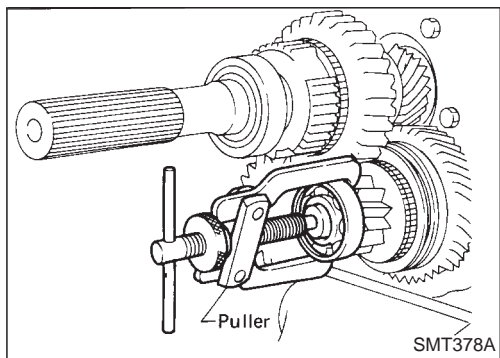

- d. Pull out counter gear ring and bearing.
- e. Remove reverse idler gear and reverse idler thrust washers.

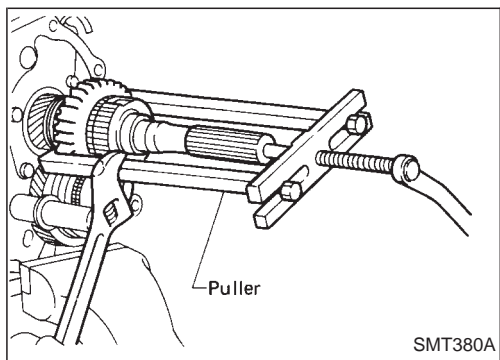

- f. Pull out reverse main gear together with mainshaft spacer and reverse synchronizer hub. Then remove reverse gear needle bearings.

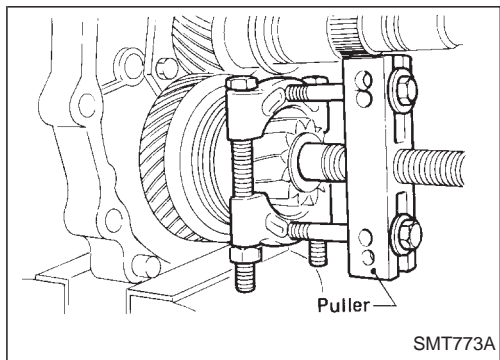

- g. Pull out reverse counter gear.
- h. Remove OD coupling sleeve together with OD baulk ring, reverse baulk ring and spring inserts.

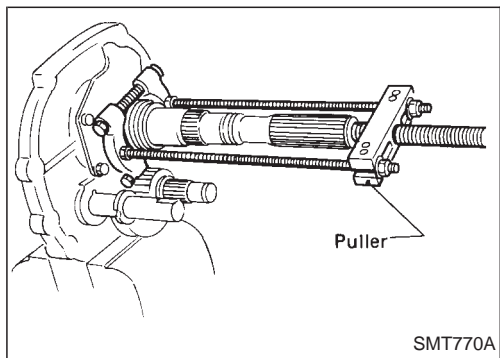

- i. Pull out reverse gear bushing.

DISASSEMBLY

Gear Components (Cont'd)

- j. Pull out OD counter gear together with reverse cone.

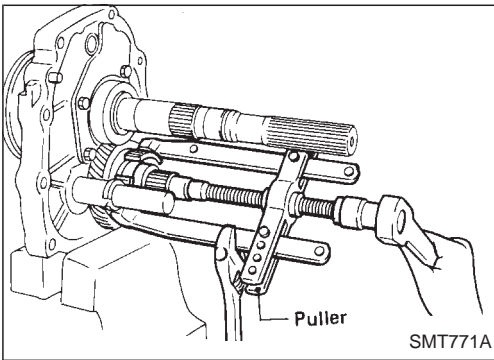

- 3. Press out mainshaft and counter gear alternately.

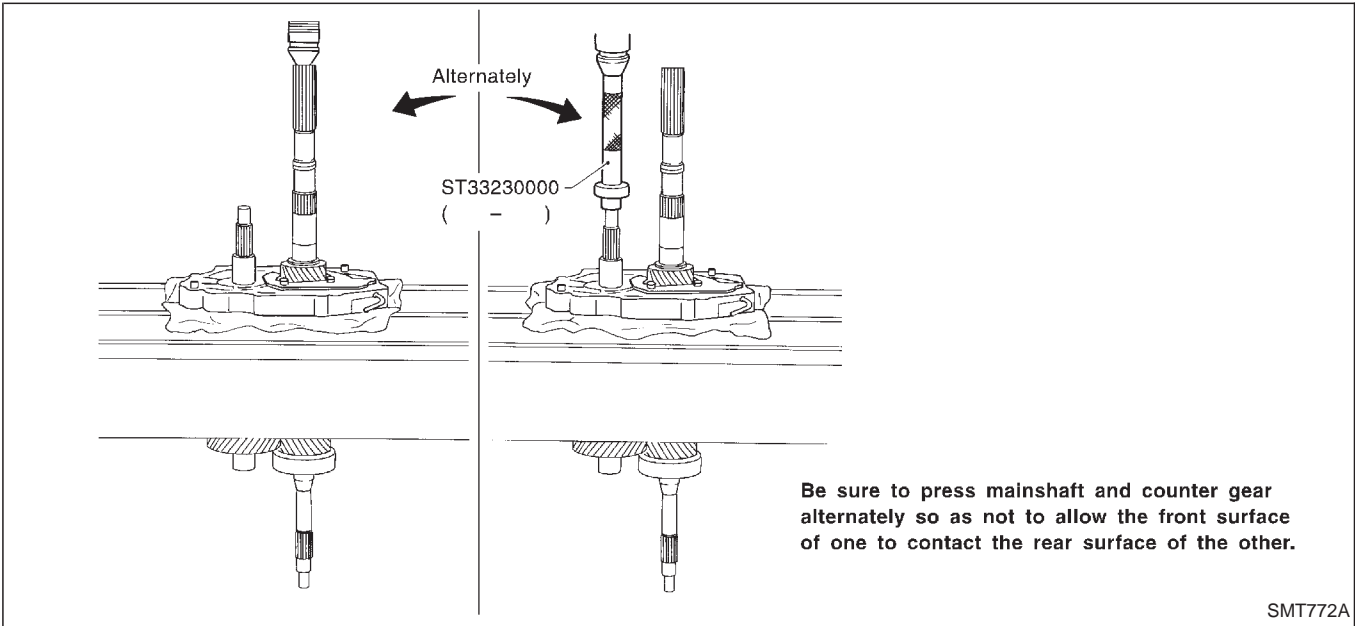

- 4. Remove front side components on mainshaft.
 - a. Remove 1st gear washer and steel ball.
 - b. Remove 1st main gear and 1st gear needle bearing.

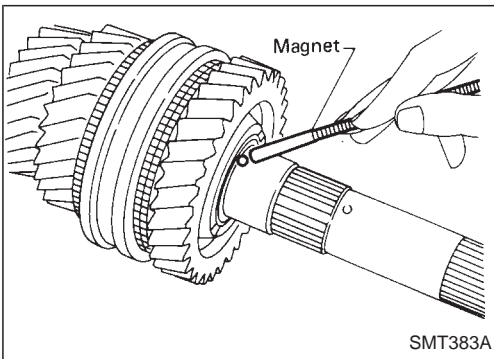

- c. Press out 2nd main gear together with 1st gear bushing and 1st & 2nd synchronizer assembly.
 - d. Remove mainshaft front snap ring.

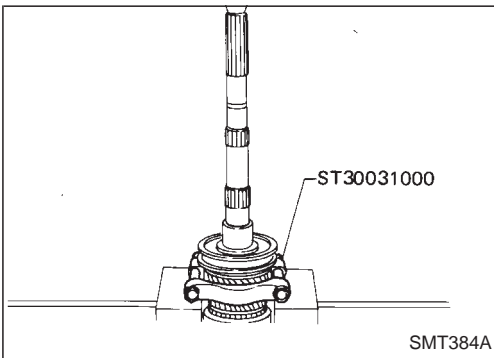

DISASSEMBLY

Gear Components (Cont'd)

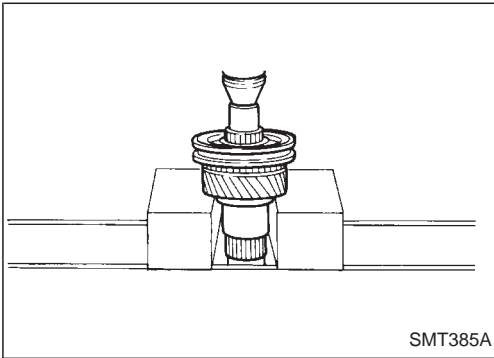

- e. Press out 3rd main gear together with 3rd & 4th synchronizer assembly and 3rd gear needle bearing.

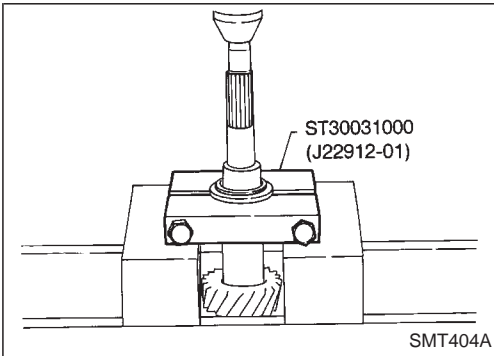

5. Remove front side components on counter gear.
 - a. Remove counter gear rear thrust bearing.

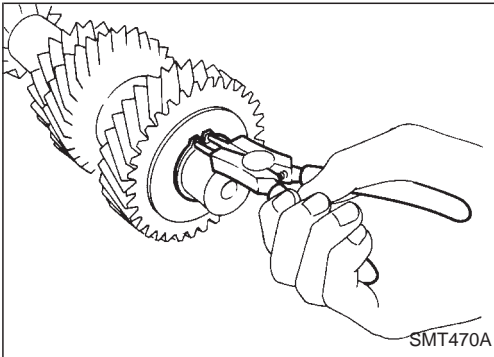

- b. Remove sub-gear components.

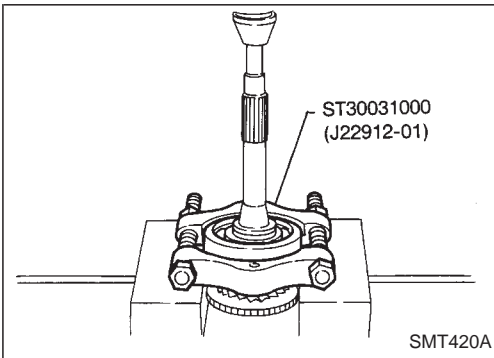

6. Remove main drive gear bearing.
 - a. Remove main drive gear snap ring and spacer.
 - b. Press out main drive gear bearing.

DISASSEMBLY

Gear Components (Cont'd)

7. Remove bearings from case components.

Counter gear front bearing in transmission case

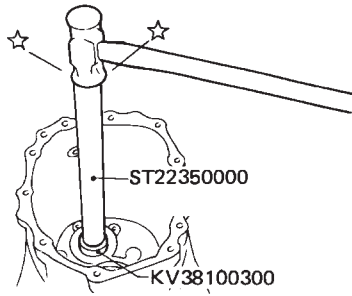

SMT388A

Mainshaft front bearing in adapter plate

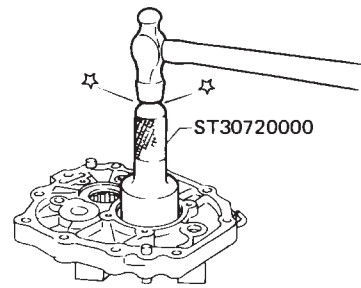

SMT396A

Counter gear rear bearing in adapter plate

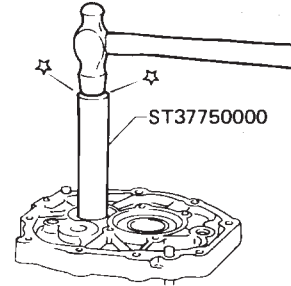

SMT394A

INSPECTION

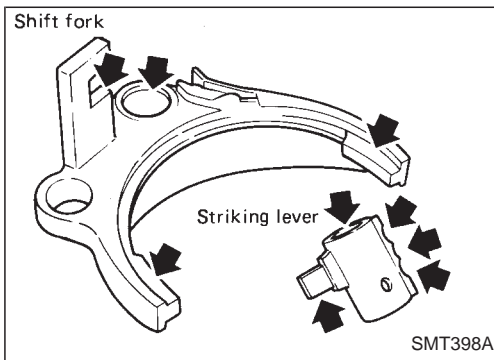

Shift Control Components

- Check contact surface and sliding surface for wear, scratches, projections or other damage.

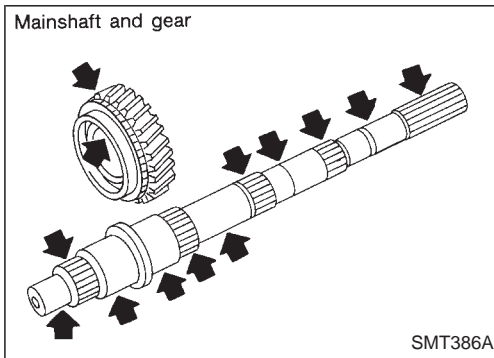

Gear Components

GEARS AND SHAFTS

- Check shafts for cracks, wear or bending.
- Check gears for excessive wear, chips or cracks.

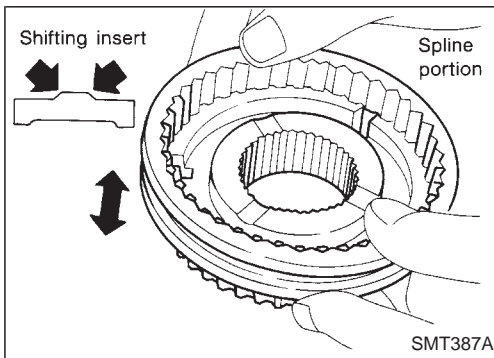
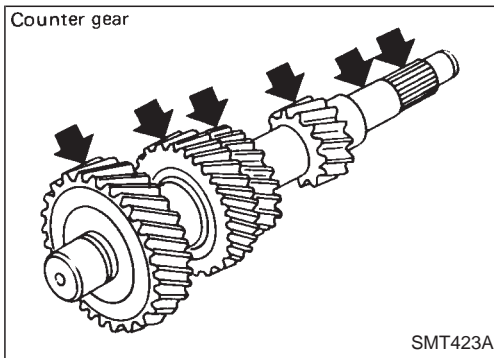

SYNCHRONIZERS

- Check spline portion of coupling sleeves, hubs, and gears for wear or cracks.
- Check baulk rings for cracks or deformation.
- Check shifting inserts for wear or deformation.
- Check insert springs for deformation.

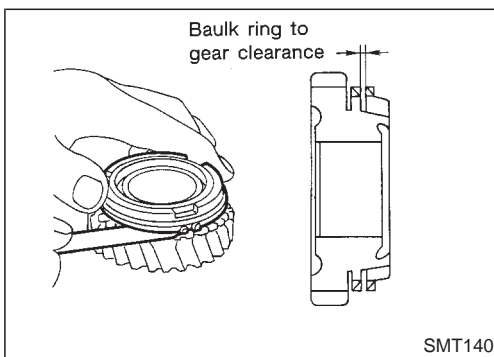

Clearance between baulk ring and gear

		Unit: mm (in)
	Standard	Wear limit
1st & 2nd	1.05 - 1.3 (0.0413 - 0.0512)	0.7 (0.028)
3rd & main drive	1.05 - 1.3 (0.0413 - 0.0512)	0.7 (0.028)
OD	1.05 - 1.3 (0.0413 - 0.0512)	0.7 (0.028)

If the clearance is smaller than the wear limit, replace baulk ring.

INSPECTION

Gear Components (Cont'd)

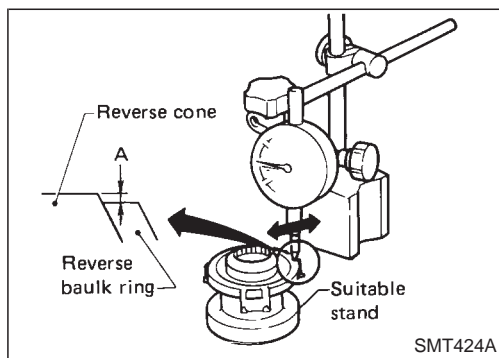

- Measure wear of reverse baulk ring.
 - a. Place baulk ring in position on reverse cone.
 - b. While holding baulk ring against reverse cone as far as it will go, measure dimension "A" with dial indicator.

Unit: mm (in)

	Standard	Wear limit
Dimension "A"	-0.1 to 0.35 (-0.0039 to 0.0138)	0.7 (0.028)

- c. If dimension "A" is larger than the wear limit, replace baulk ring.

BEARINGS

- Make sure bearings roll freely and are free from noise, cracks, pitting or wear.

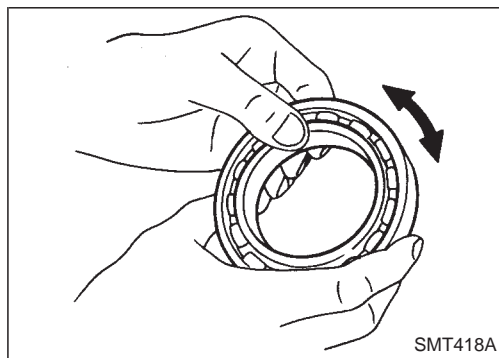

ASSEMBLY

Gear Components

1. Install bearings into case components.

Counter gear front bearing in transmission case

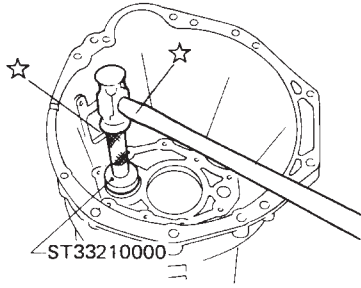

SMT389A

Mainshaft front bearing in adapter plate

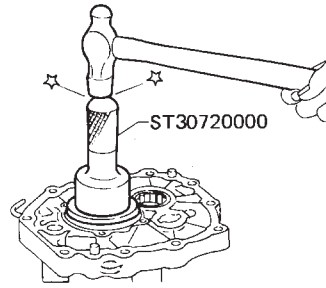

SMT397A

Counter gear rear bearing in adapter plate

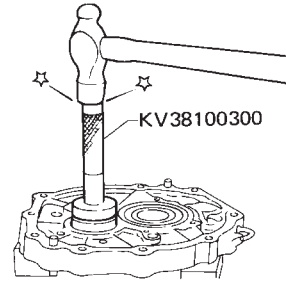

SMT395A

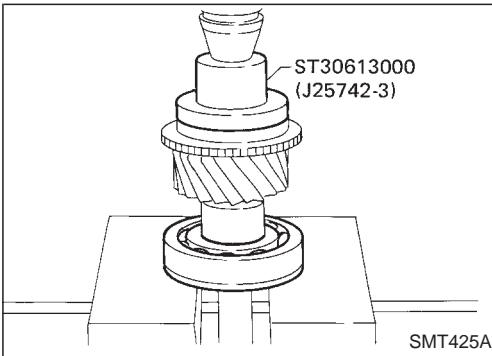

SMT425A

2. Install main drive gear bearing.
 - a. Press main drive gear bearing.
 - b. Install main drive gear spacer.

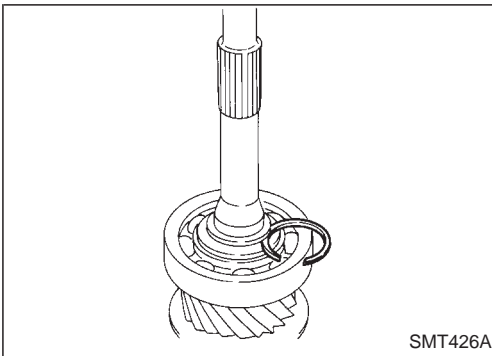

SMT426A

- c. Select proper main drive gear snap ring to minimize clearance of groove.

Allowable clearance of groove:

0 - 0.1 mm (0 - 0.004 in)

Main drive gear snap ring

Thickness mm (in)	Part number
1.89 (0.0744)	32204-01G00
1.98 (0.0780)	32204-01G01
2.05 (0.0807)	32204-01G02
2.12 (0.0835)	32204-01G03
2.19 (0.0862)	32204-01G04

ASSEMBLY

Gear Components (Cont'd)

- d. Install selected snap ring on main drive gear.

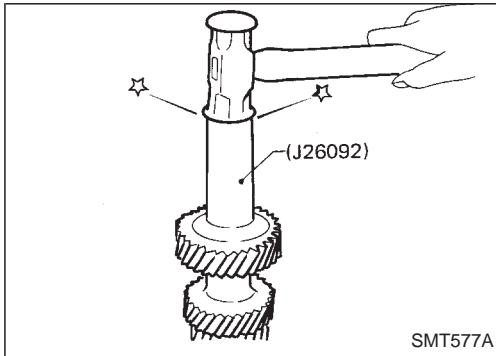

- 3. Install components on counter gear.

- a. Install sub-gear components.

When installing sub-gear snap ring, tap sub-gear snap ring into position on counter gear.

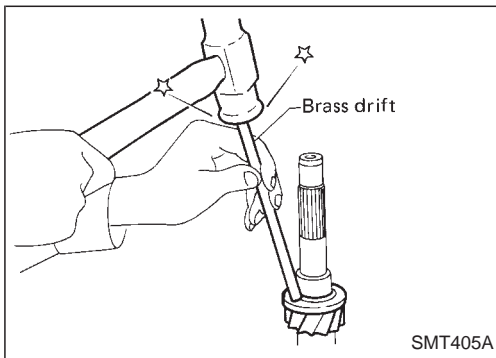

- b. Install counter gear rear thrust bearing.

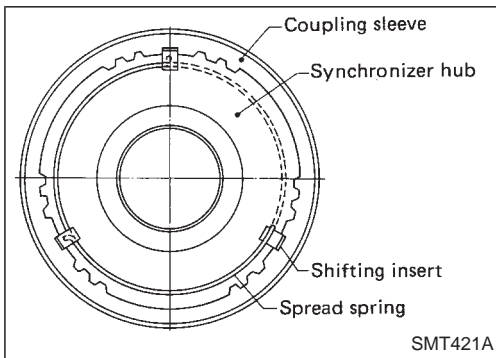

- 4. Install front side components on mainshaft.

- a. Assemble 1st & 2nd synchronizer.

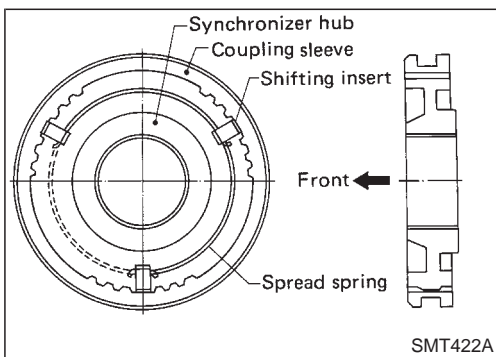

- b. Assemble 3rd & 4th synchronizer.

ASSEMBLY

Gear Components (Cont'd)

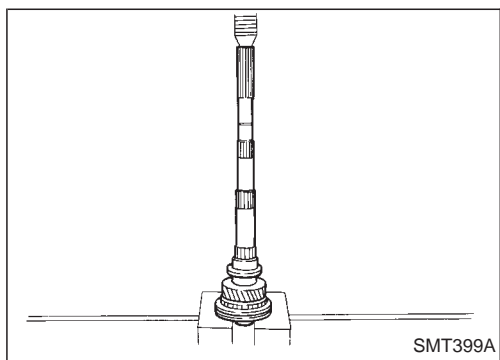

- c. Press on 3rd & 4th synchronizer assembly together with 3rd main gear and 3rd gear needle bearing.

Pay attention to direction of synchronizer assembly.

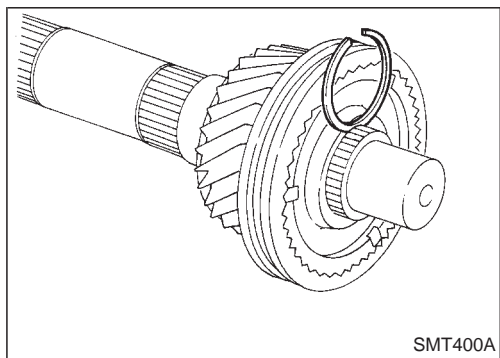

- d. Select proper snap ring to minimize clearance of groove.

Allowable clearance of groove:

0 - 0.1 mm (0 - 0.004 in)

Mainshaft front snap ring

Thickness mm (in)	Part number
1.89 (0.0744)	32204-01G00
1.98 (0.0780)	32204-01G01
2.05 (0.0807)	32204-01G02
2.12 (0.0835)	32204-01G03
2.19 (0.0862)	32204-01G04

- e. Install selected snap ring on mainshaft.

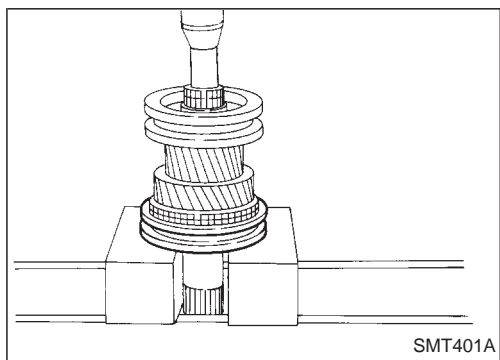

- f. Press on 1st & 2nd synchronizer assembly together with 2nd main gear and 2nd gear needle bearing.

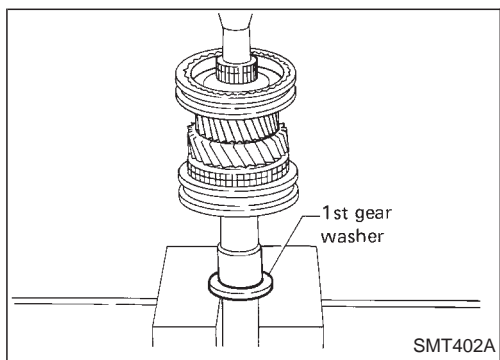

- g. Press on 1st gear bushing using 1st gear washer.

- h. Install 1st main gear and needle bearing.

ASSEMBLY

Gear Components (Cont'd)

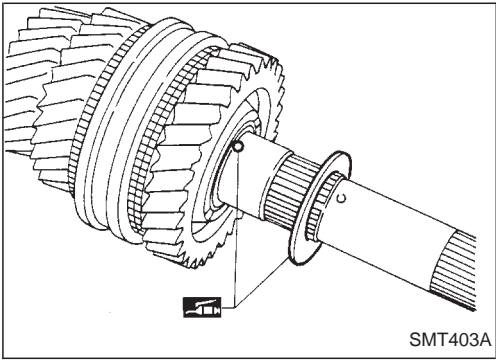

- i. Install steel ball and 1st gear washer.
Apply multi-purpose grease to steel ball and 1st gear washer before installing.

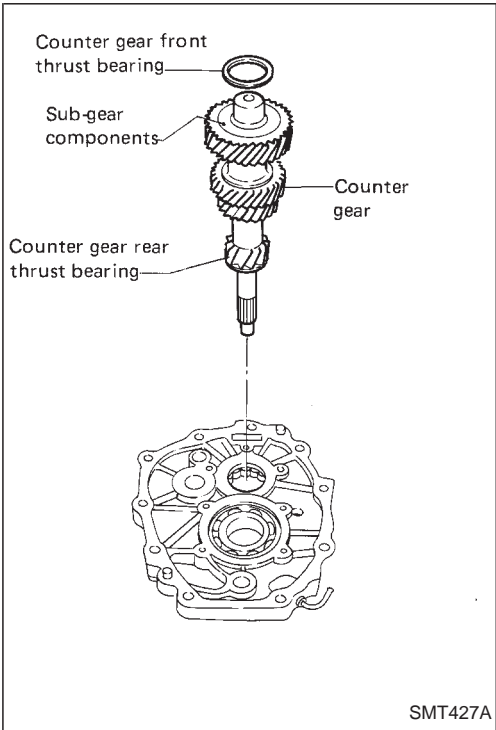

- 5. Select proper counter gear front bearing shim when replacing transmission case, counter gear, counter gear thrust bearing or sub-gear components.
 - a. Install counter gear with sub-gear components, counter gear front and rear thrust bearing on adapter plate.
 - b. Remove counter gear front bearing shim from transmission case.
 - c. Place adapter plate and counter gear assembly in transmission case (case inverted).

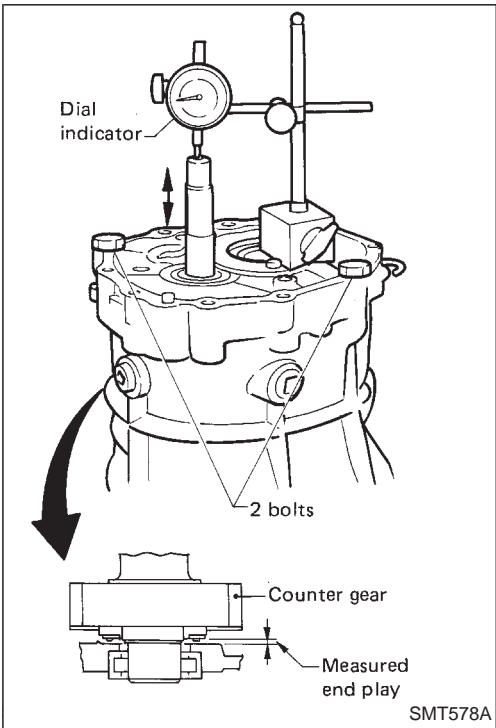

- d. Tighten adapter plate to transmission case using 2 bolts.
- e. Place dial indicator on rear end of counter gear.
- f. Move counter gear up and down and measure dial indicator deflection.
- g. Select proper shim using table below as a guide.

**Counter gear end play:
0.10 - 0.25 mm (0.0039 - 0.0098 in)**

Table for selecting proper counter gear front bearing shim

Dial indicator deflection mm (in)	Thickness of proper washer mm (in)	Part number
0.93 - 1.02 (0.0366 - 0.0402)	0.88 (0.0346)	32216-01G11
1.03 - 1.12 (0.0406 - 0.0441)	0.96 (0.0378)	32216-01G12
1.13 - 1.22 (0.0445 - 0.0480)	1.04 (0.0409)	32216-01G13
1.23 - 1.32 (0.0484 - 0.0520)	1.12 (0.0441)	32216-01G14
1.33 - 1.42 (0.0524 - 0.0559)	1.28 (0.0504)	32216-01G15
1.43 - 1.52 (0.0563 - 0.0598)	1.36 (0.0535)	32216-01G16
1.53 - 1.62 (0.0602 - 0.0638)	1.44 (0.0567)	32216-01G17

ASSEMBLY

Gear Components (Cont'd)

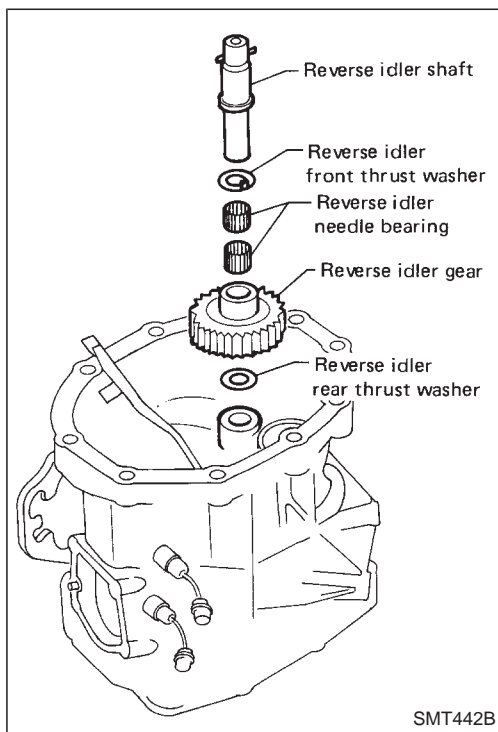

6. Select proper reverse idler rear thrust washer when replacing OD gear case, reverse idler gear, reverse idler shaft or reverse idler thrust washer.
 - a. Install reverse idler gear, reverse idler needle bearings, reverse idler thrust washers and reverse idler shaft into OD gear case.

When replacing reverse idler rear washer, install either A or B. Reverse idler rear thrust washer.

	Thickness mm (in)	Part number
A	1.97 (0.0776)	32284-01G10
B	2.07 (0.0815)	32284-01G11

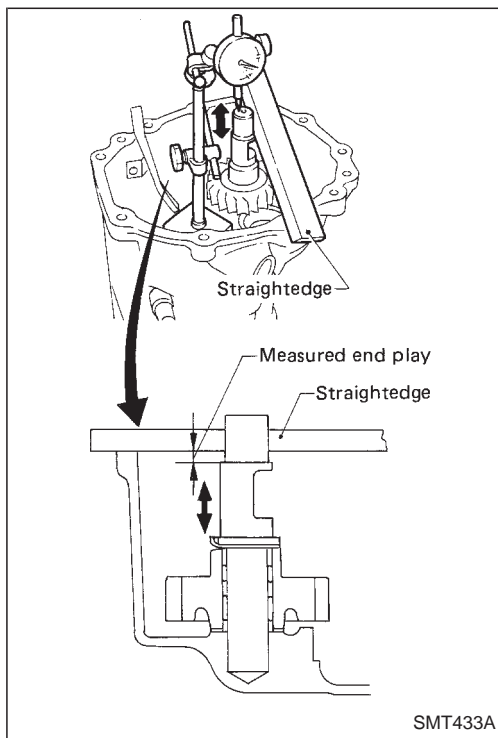

- b. Place dial indicator on front end of reverse idler shaft.
- c. Put straightedge on front surface of OD gear case as a stopper for reverse idler shaft.
- d. Move reverse idler shaft up and down and measure reverse idler gear end play.

Reverse idler gear end play:

0.30 - 0.53 mm (0.0118 - 0.0209 in)

- e. If not within specification, replace reverse idler rear thrust washer with the other (A or B) and check again.

ASSEMBLY

Gear Components (Cont'd)

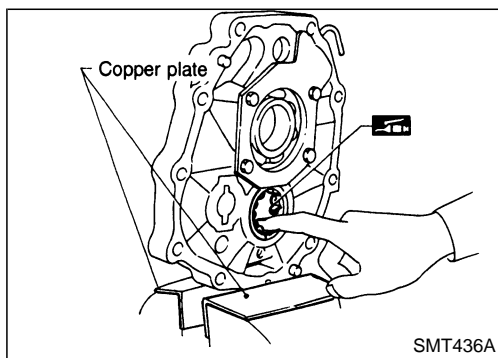

7. Install mainshaft and counter gear on adapter plate and main drive gear on mainshaft.
 - a. Mount adapter plate on vise and apply multi-purpose grease to counter gear rear bearing.

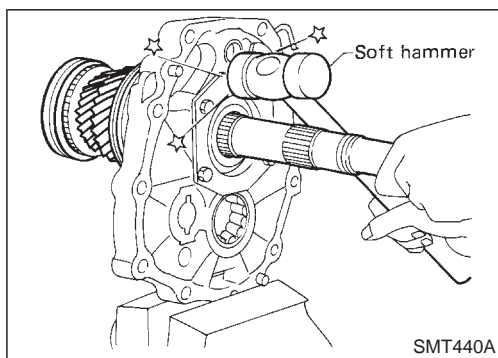

- b. Install mainshaft a little on mainshaft front bearing.
To allow for installation of counter gear, do not install mainshaft completely.

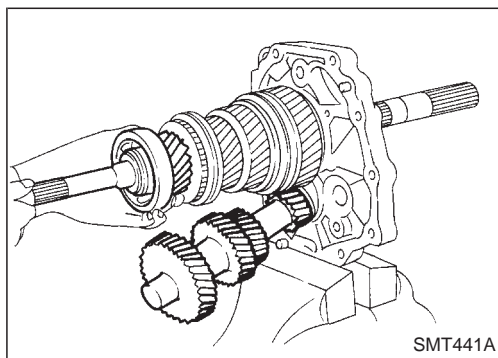

- c. Install counter gear on counter gear rear bearing and install main drive gear, pilot bearing and spacer on mainshaft.

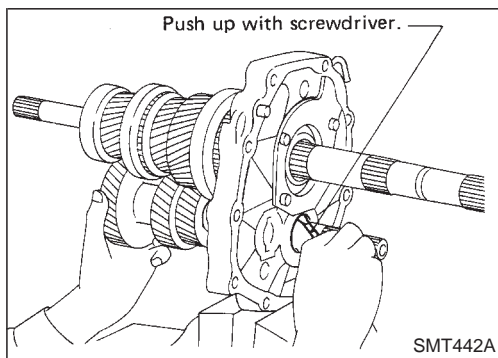

When installing counter gear into counter gear rear bearing, push up on upper roller of counter gear rear bearing with screwdriver.

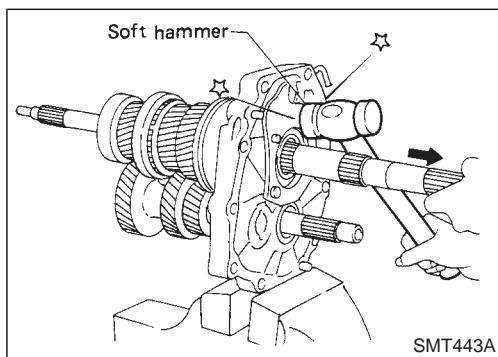

- d. Install mainshaft and counter gear completely by tapping rear side of adapter plate and pulling mainshaft.

ASSEMBLY

Gear Components (Cont'd)

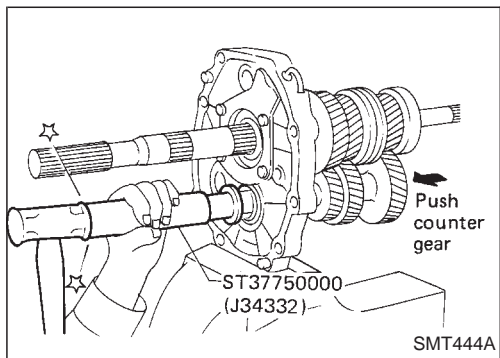

8. Install rear side components on mainshaft and counter gear.
 - a. Install OD gear bushing while pushing on the front of counter gear.

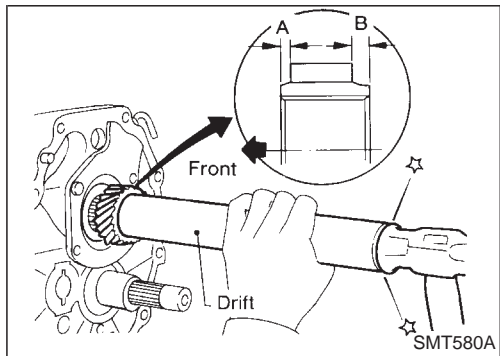

- b. Install OD main gear.
Pay attention to direction of OD main gear. (B is wider than A as shown at left.)
 - c. Install adapter plate with gear assembly onto transmission case.
 - d. Install OD gear needle bearing and then install OD counter gear and reverse idler shaft.

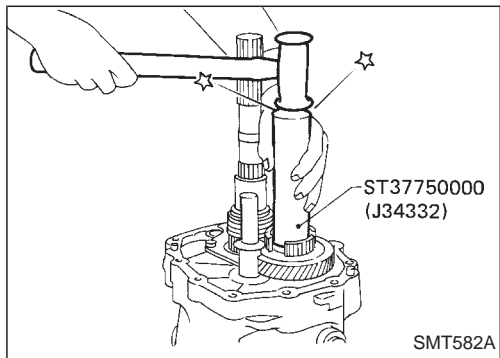

- e. Install reverse cone.

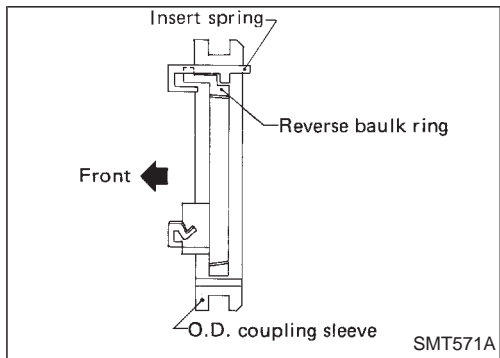

- f. Install insert springs and reverse baulk ring on OD coupling sleeve. Then install them and OD baulk ring on OD counter gear.
Pay attention to direction of OD coupling sleeve.

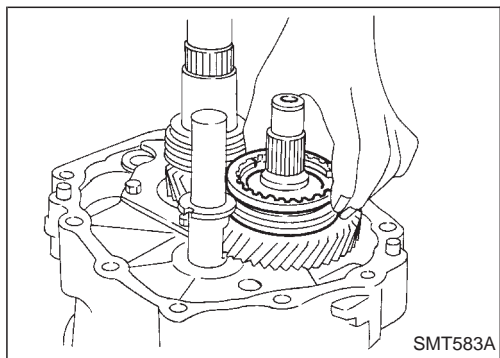

ASSEMBLY

Gear Components (Cont'd)

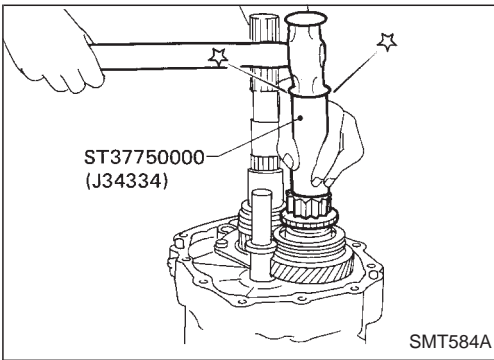

- g. Install reverse counter gear.
- h. Install reverse gear needle bearing and then install reverse main gear, reverse idler gear and reverse idler thrust washers.

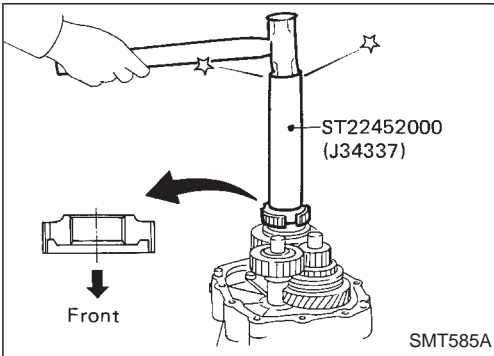

- i. Install reverse hub.
Pay attention to its direction.

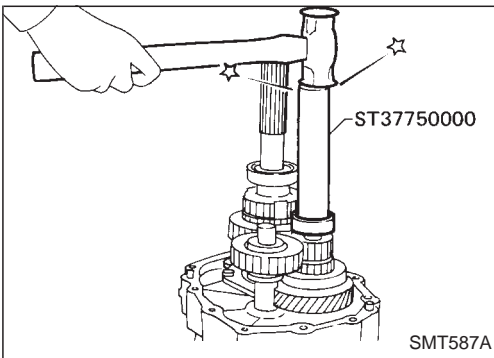

- j. Install counter rear gear end bearing.
- k. Separate adapter plate from transmission case and mount adapter plate on vice again.

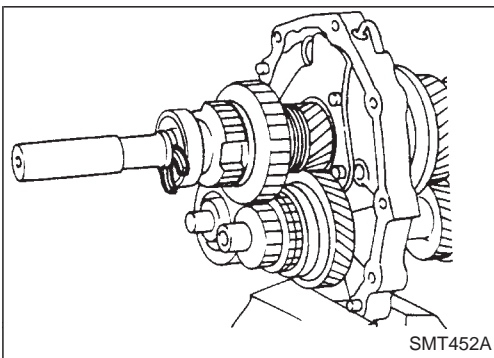

- l. Select proper mainshaft C-ring to minimize clearance of groove.

**Allowable clearance of groove:
0 - 0.1 mm (0 - 0.004 in)**

Mainshaft C-ring

Thickness mm (in)	Part number	Thickness mm (in)	Part number
2.63 (0.1035)	32348-01G15	3.19 (0.1256)	32348-01G07
2.70 (0.1063)	32348-01G00	3.26 (0.1283)	32348-01G08
2.77 (0.1091)	32348-01G01	3.33 (0.1311)	32348-01G09
2.84 (0.1118)	32348-01G02	3.40 (0.1339)	32348-01G10
2.91 (0.1146)	32348-01G03	3.47 (0.1366)	32348-01G11
2.98 (0.1173)	32348-01G04	3.54 (0.1394)	32348-01G12
3.05 (0.1201)	32348-01G05	3.61 (0.1421)	32348-01G13
3.12 (0.1228)	32348-01G06	3.68 (0.1449)	32348-01G14

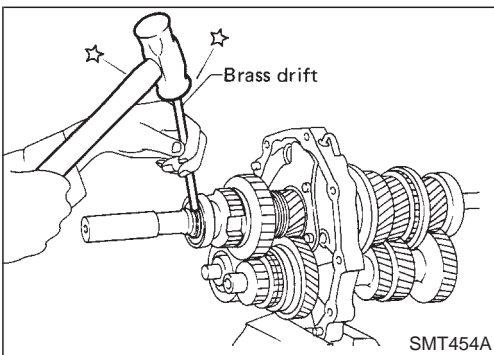

- m. Install selected C-ring, C-ring holder and mainshaft rear snap ring.

ASSEMBLY

Gear Components (Cont'd)

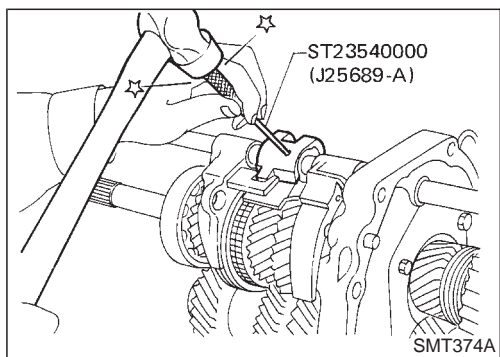
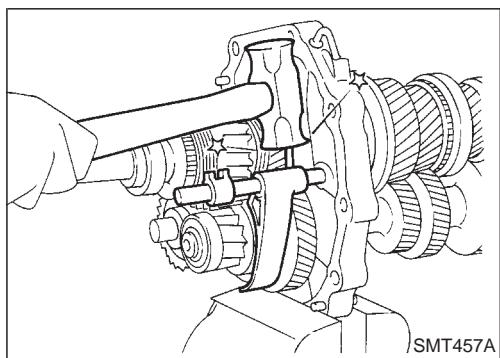
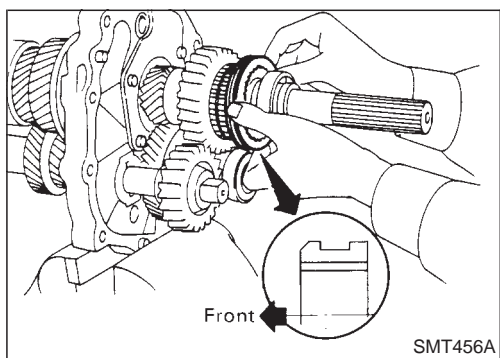
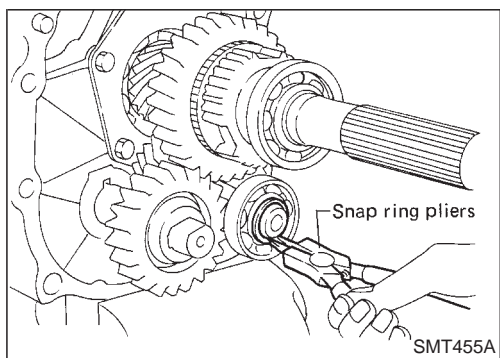
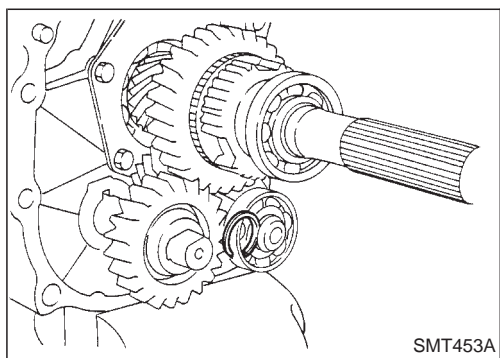

- n. Install spacer and then select proper counter gear rear snap ring to minimize clearance of groove.

Allowable clearance of groove:

0 - 0.1 mm (0 - 0.004 in)

Counter gear rear snap ring

Thickness mm (in)	Part number
1.26 (0.0496)	32236-01G08
1.32 (0.0520)	32236-01G00
1.38 (0.0543)	32236-01G01
1.44 (0.0567)	32236-01G02
1.50 (0.0591)	32236-01G03
1.56 (0.0614)	32236-01G04
1.62 (0.0638)	32236-01G05
1.68 (0.0661)	32236-01G06
1.74 (0.0685)	32236-01G07

- o. Install selected counter gear rear snap ring.

- p. Install reverse coupling sleeve.

Pay attention to its direction.

- q. Measure each gear end play as a final check. — Refer to “DISASSEMBLY”, MT-14.

Shift Control Components

1. Install OD fork rod and OD shift fork. Then install retaining pin into OD shift fork.
2. Install 1st & 2nd, 3rd & 4th and reverse shift fork onto coupling sleeve.

3. Install striking rod into hole of shift forks, striking lever and interlock and then install retaining pin into striking lever.

Make sure that striking rod moves smoothly.

ASSEMBLY

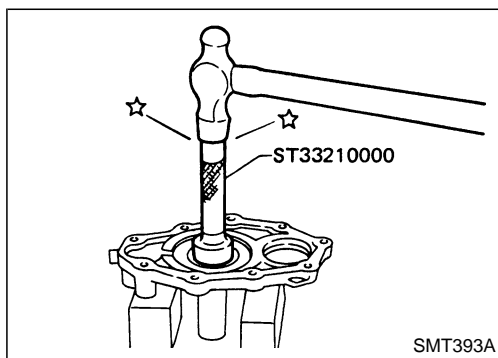

Case Components

1. Install front cover oil seal.
Apply multi-purpose grease to seal lip.
2. Install selected counter gear front bearing shim onto transmission case.
Apply multi-purpose grease.
3. Apply sealant to mating surface of transmission case.

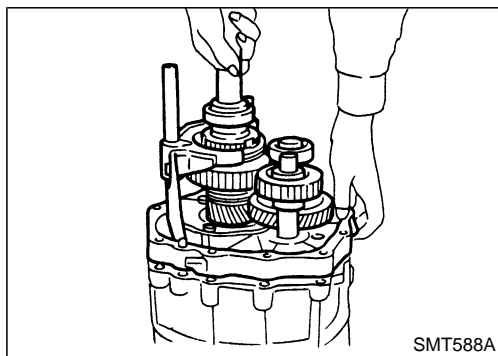

4. Install gear assembly onto transmission case.
5. Install check spring and check ball into interlock stopper.
Apply multi-purpose grease to check ball.

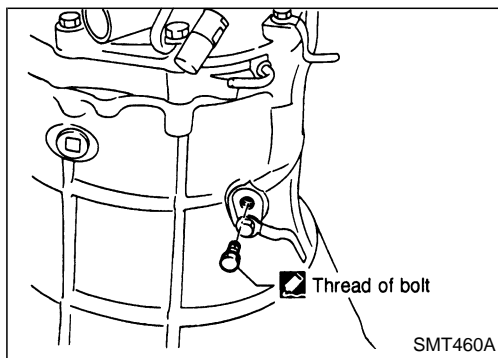

6. Install interlock stopper assembly and then tighten check ball plug.
Apply sealant to thread of check ball plug.

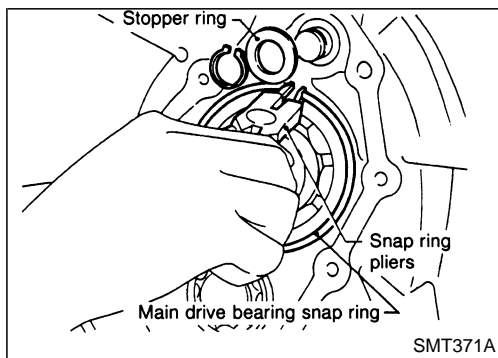

7. Install stopper ring and main drive bearing snap ring.

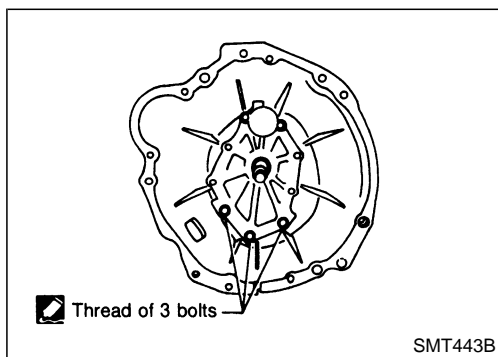

8. Install front cover and gasket.
Apply sealant to thread of 3 bolts shown left.
9. Apply sealant to mating surface of adapter plate.

ASSEMBLY

Case Components (Cont'd)

10. Install OD gear case together with striking arm.

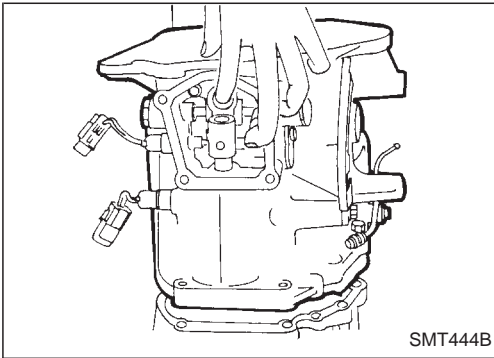

11. Install retaining pin into striking arm.

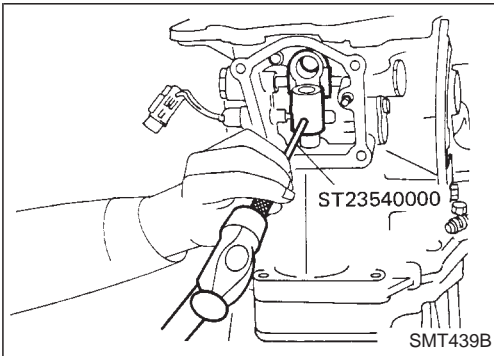

12. Install return spring and check ball and then install control housing.

Apply sealant to mating surface of OD gear case.

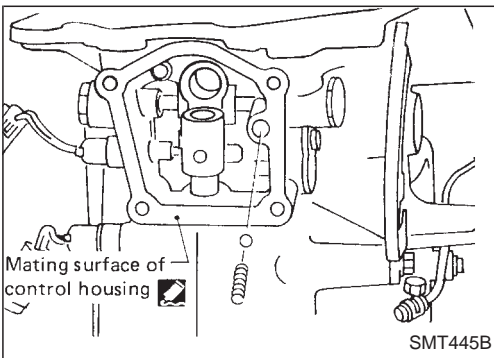

13. Tighten control housing bolts.

Bolt head size:

A bolts 12 mm

B bolts 13 mm

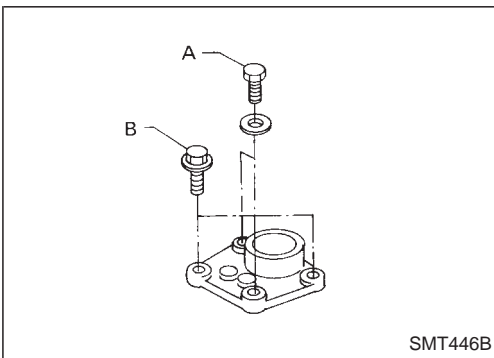

SERVICE DATA AND SPECIFICATIONS (SDS)

General Specifications

Engine	TD27Ti and ZD30DDTi
Transmission model	FS5R30A
No. of speeds	5
Shift pattern	
Synchromesh type	Warner
Gear ratio	
1st	3.580
2nd	2.077
3rd	1.360
4th	1.000
OD	0.811
Reverse	3.631
No. of teeth	
Mainshaft	
drive	
1st	32
2nd	30
3rd	29
4th	22
OD	24
Reverse	30
Countershaft	
Drive	
1st	13
2nd	21
3rd	31
4th	32
OD	43
Reverse	12
Reverse idler gear	22
Oil capacity ℓ (Imp pt)	3.6 (6-3/8)

SERVICE DATA AND SPECIFICATIONS (SDS)

Inspection and Adjustment

GEAR END PLAY

Gear	End play mm (in)
1st main gear	0.23 - 0.33 (0.0091 - 0.0130)
2nd main gear	0.23 - 0.33 (0.0091 - 0.0130)
3rd main gear	0.23 - 0.33 (0.0091 - 0.0130)
OD counter gear	0.23 - 0.33 (0.0091 - 0.0130)
Reverse main gear	0.33 - 0.43 (0.0130 - 0.0169)
Counter gear	0.10 - 0.25 (0.0039 - 0.0098)
Reverse idler gear	0.30 - 0.53 (0.0118 - 0.0209)

CLEARANCE BETWEEN BAULK RING AND GEAR

Unit: mm (in)

	Standard	Wear limit
1st & 2nd	1.05 - 1.3 (0.0413 - 0.0512)	0.7 (0.028)
3rd & main-drive	1.05 - 1.3 (0.0413 - 0.0512)	0.7 (0.028)
OD	1.05 - 1.3 (0.0413 - 0.0512)	0.7 (0.028)

DISTANCE BETWEEN REAR SURFACE OF REVERSE CONE AND REVERSE BAULK RING

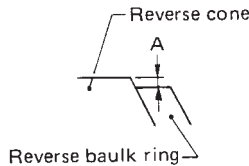

Unit: mm (in)

Dimension "A"	Standard	Wear limit
	-0.1 to 0.36 (-0.0039 to 0.0142)	0.7 (0.028)

AVAILABLE SNAP RING

Main drive gear snap ring

Allowable clearance		0 - 0.1 mm (0 - 0.004 in)	
Thickness mm (in)	Part number	Thickness mm (in)	Part number
1.89 (0.0744)	32204-01G00		
1.98 (0.0780)	32204-01G01		
2.05 (0.0807)	32204-01G02		
2.12 (0.0835)	32204-01G03		
2.19 (0.0862)	32204-01G04		

Mainshaft front snap ring

Allowable clearance		0 - 0.1 mm (0 - 0.004 in)	
Thickness mm (in)	Part number	Thickness mm (in)	Part number
1.89 (0.0744)	32204-01G00		
1.98 (0.0780)	32204-01G01		
2.05 (0.0807)	32204-01G02		
2.12 (0.0835)	32204-01G03		
2.19 (0.0862)	32204-01G04		

Counter gear rear snap ring

Allowable clearance		0 - 0.1 mm (0 - 0.004 in)	
Thickness mm (in)	Part number	Thickness mm (in)	Part number
1.26 (0.0496)	32236-01G08		
1.32 (0.0520)	32236-01G00		
1.38 (0.0543)	32236-01G01		
1.44 (0.0567)	32236-01G02		
1.50 (0.0591)	32236-01G03		
1.56 (0.0614)	32236-01G04		
1.62 (0.0638)	32236-01G05		
1.68 (0.0661)	32236-01G06		
1.74 (0.0685)	32236-01G07		

AVAILABLE C-RING

Mainshaft C-ring

Allowable clearance				0 - 0.1 mm (0 - 0.004 in)			
Thickness mm(in)	Part number	Thickness mm (in)	Part number	Thickness mm (in)	Part number	Thickness mm (in)	Part number
2.63 (0.1035)	32348-01G15	3.19 (0.1256)	32348-01G07				
2.70 (0.1063)	32348-01G00	3.26 (0.1283)	32348-01G08				
2.77 (0.1091)	32348-01G01	3.33 (0.1311)	32348-01G09				
2.84 (0.1118)	32348-01G02	3.40 (0.1339)	32348-01G10				
2.91 (0.1146)	32348-01G03	3.47 (0.1366)	32348-01G11				
2.98 (0.1173)	32348-01G04	3.54 (0.1394)	32348-01G12				
3.05 (0.1201)	32348-01G05	3.61 (0.1421)	32348-01G13				
3.12 (0.1228)	32348-01G06	3.68 (0.1449)	32348-01G14				

SERVICE DATA AND SPECIFICATIONS (SDS)

Inspection and Adjustment (Cont'd)

AVAILABLE SHIM AND WASHER

Table for selecting proper counter gear front bearing shim

Dial indicator deflection mm (in)	Thickness of proper washer mm (in)	Part number
0.93 - 1.02 (0.0366 - 0.0402)	0.88 (0.0346)	32218-01G11
1.03 - 1.12 (0.0406 - 0.0441)	0.96 (0.0378)	32218-01G12
1.13 - 1.22 (0.0445 - 0.0480)	1.04 (0.0409)	32218-01G13
1.23 - 1.32 (0.0484 - 0.0520)	1.12 (0.0441)	32218-01G14
1.33 - 1.42 (0.0524 - 0.0559)	1.28 (0.0504)	32218-01G15
1.43 - 1.52 (0.0563 - 0.0598)	1.36 (0.0535)	32218-01G16
1.53 - 1.62 (0.0602 - 0.0638)	1.44 (0.0567)	32218-01G17

Reverse idler rear thrust washer

Thickness mm (in)	Part number
1.97 (0.0776)	32284-01G10
2.07 (0.0815)	32284-01G11